



# QR500 Series

CASE

XASTRA



## Case Features

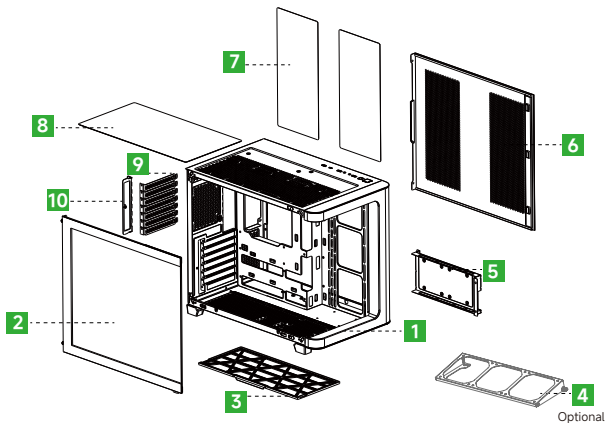

1. Chassis

2. Tempered Glass Panel

3. Bottom Dust Filter

4. Fan Bracket (Optional)

5. SDD&HDD Tray

6. Side Panel

7. Side Panel Dust Filter

8. Top Filter

9. PCI Insert

10. PCI Retention Bracket

# Accessory Kit Contents

**A**



**x6**

**B**



**x18**

**C**



**x9**

**D**



**x3**

**E**



**x1**

**F**



**x6**

## Panel Removal

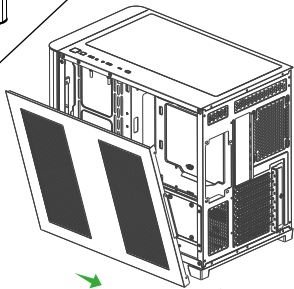
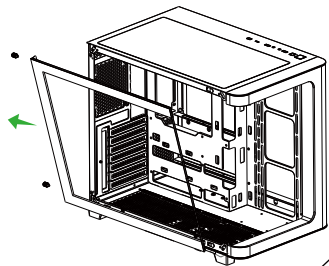

## PCI-e Slots Removal

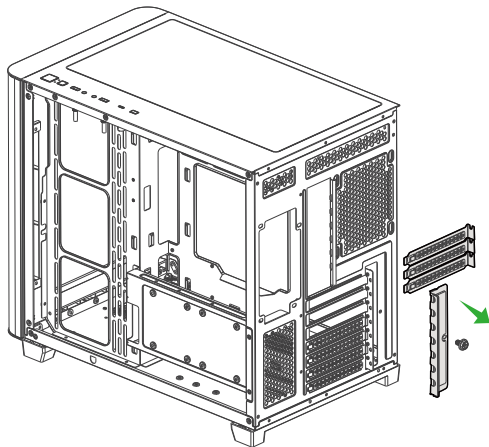

# Motherboards Installation

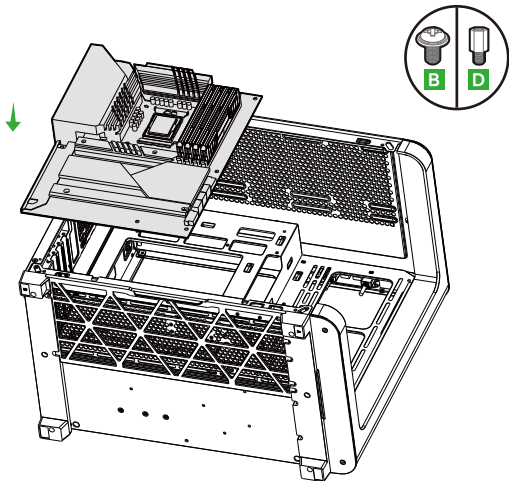

## Graphic cards Installation

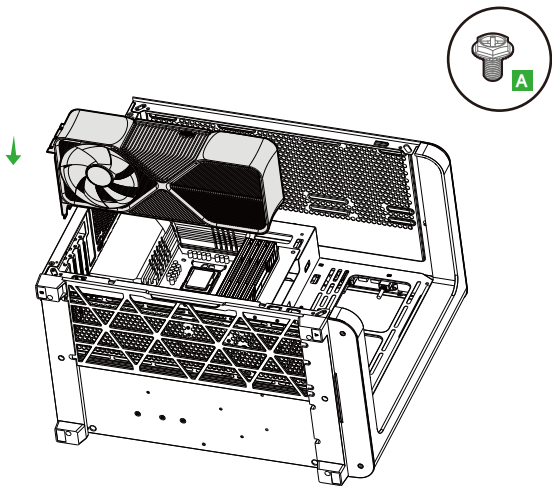

## Power supplies Installation

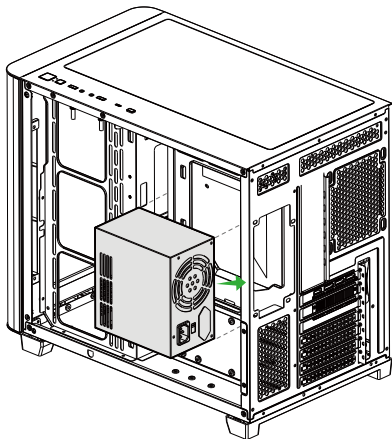

## Storage Installation 1-1

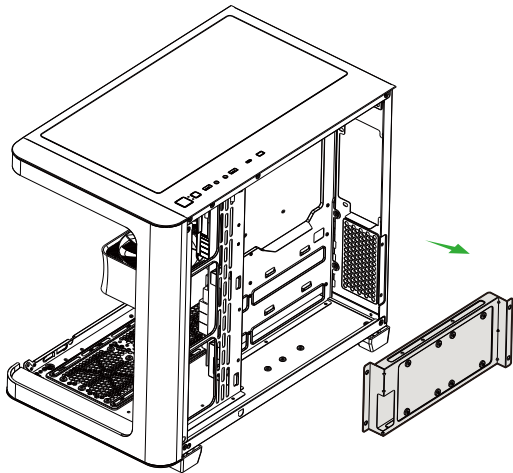

## Storage Installation 1-2

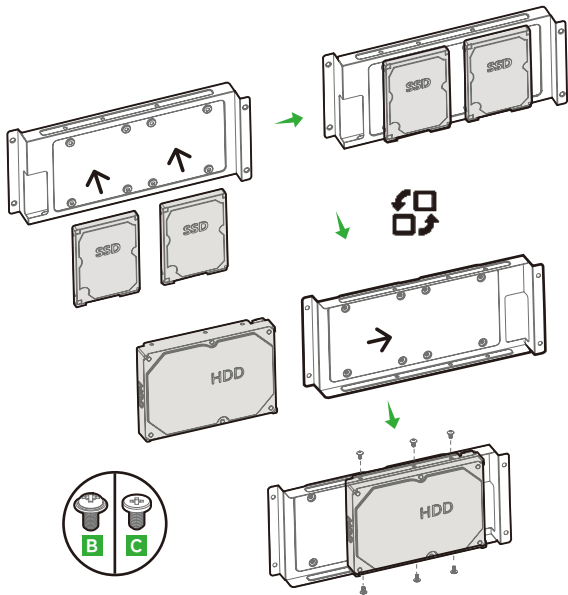

## Storage Installation 2-1

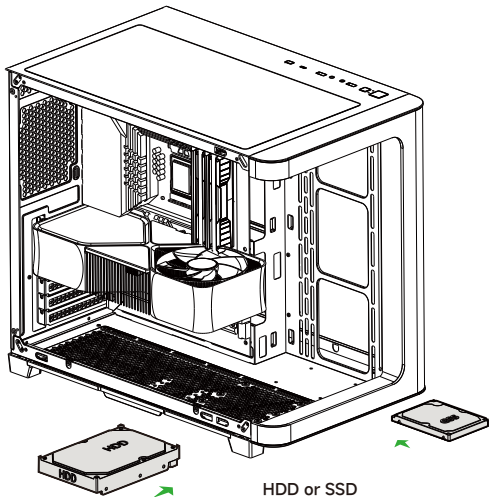

## Storage Installation 2-2

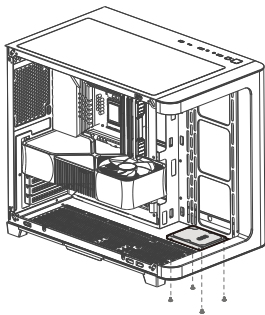
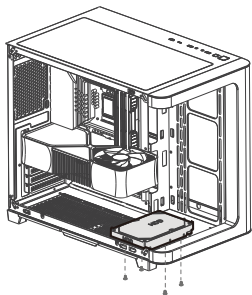

# Fans Installation

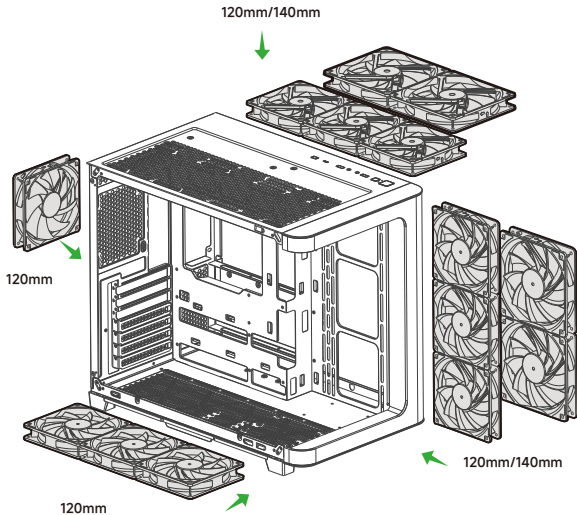

# Radiators Installation

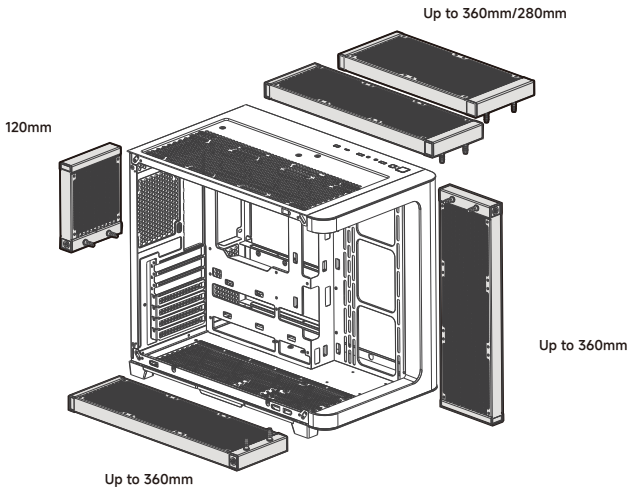

## Pull-out Dust Filter

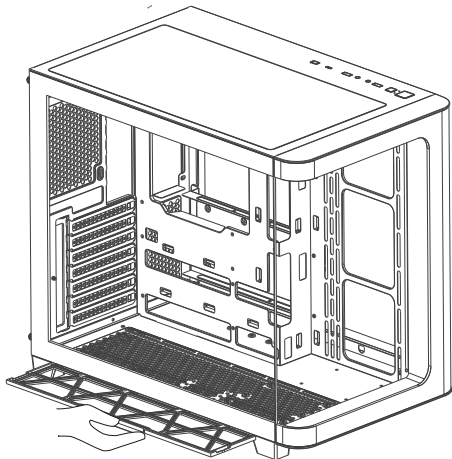

## Fan Hub(Optional)

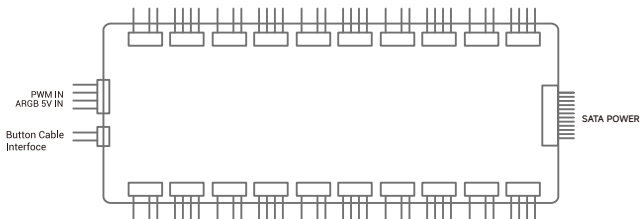

ARGB 5V OUT



PWM

- EN** For more information, please check our website at: [www.xastrapc.com](http://www.xastrapc.com)
- DE** Für weitere Informationen besuchen Sie bitte unsere Website unter: [www.xastrapc.com](http://www.xastrapc.com)
- FR** Pour plus d'informations, merci de visiter notre site internet: [www.xastrapc.com](http://www.xastrapc.com)
- ES** Para más información, por favor, visite nuestra página en: [www.xastrapc.com](http://www.xastrapc.com)
- IT** Per ulteriori informazioni, visitate il nostro sito web: [www.xastrapc.com](http://www.xastrapc.com)
- PT** Para mais informação, visita o nosso website em: [www.xastrapc.com](http://www.xastrapc.com)
- CS** Další informace najdete na našich webových stránkách: [www.xastrapc.com](http://www.xastrapc.com)
- KO** 자세한 내용은 [www.xastrapc.com](http://www.xastrapc.com) 에서 확인하실 수 있습니다
- AR** للمزيد من المعلومات , يرجى زيارة موقعنا على [www.xastrapc.com](http://www.xastrapc.com)
- TH** สำหรับข้อมูลเพิ่มเติม กรุณาเยี่ยมชมเว็บไซต์ของเรา: [www.xastrapc.com](http://www.xastrapc.com)
- SV** För mer information, gå till vår hemsida på: [www.xastrapc.com](http://www.xastrapc.com)
- PL** Więcej informacji można znaleźć na naszej stronie internetowej: [www.xastrapc.com](http://www.xastrapc.com)
- TR** Daha Fazla bilgi için, lütfen websitemizi ziyaret ediniz: [www.xastrapc.com](http://www.xastrapc.com)
- RU** Корпус для ПК. Больше информации на сайте: [www.xastrapc.com](http://www.xastrapc.com)
- KK** Көбірек ақпарат алу үшін біздің вебсайтымызға кіріңіз: [www.xastrapc.com](http://www.xastrapc.com)
- JA** 詳細については、以下URL先の公式WEBサイトをご確認ください: [www.xastrapc.com](http://www.xastrapc.com)
- VI** Để biết thêm chi tiết, vui lòng kiểm tra tại website: [www.xastrapc.com](http://www.xastrapc.com)
- ZH** 如需要更多信息, 请浏览网站: [www.xastrapc.com](http://www.xastrapc.com)
- ZH** 如需要更多信息 請瀏覽網站: [www.xastrapc.com](http://www.xastrapc.com)

Manufacture: SHENZHEN XASTRA TECHNOLOGY CO.,LTD

E-mail: [support@xastrapc.com](mailto:support@xastrapc.com)





[www.xastrapc.com](http://www.xastrapc.com)